

SCHICHTENLINIEN UND HÖHEN
SIND AUF DIE HÖHE DER RWY THR 16 BEZOGEN (182,0M)
CONTOURS AND HEIGHTS
ARE RELATED TO ELEVATION OF RWY THR 16 (182,0M)

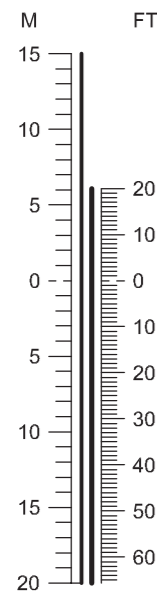

VERTIKALMASSTAB
VERTICAL SCALE
1:500

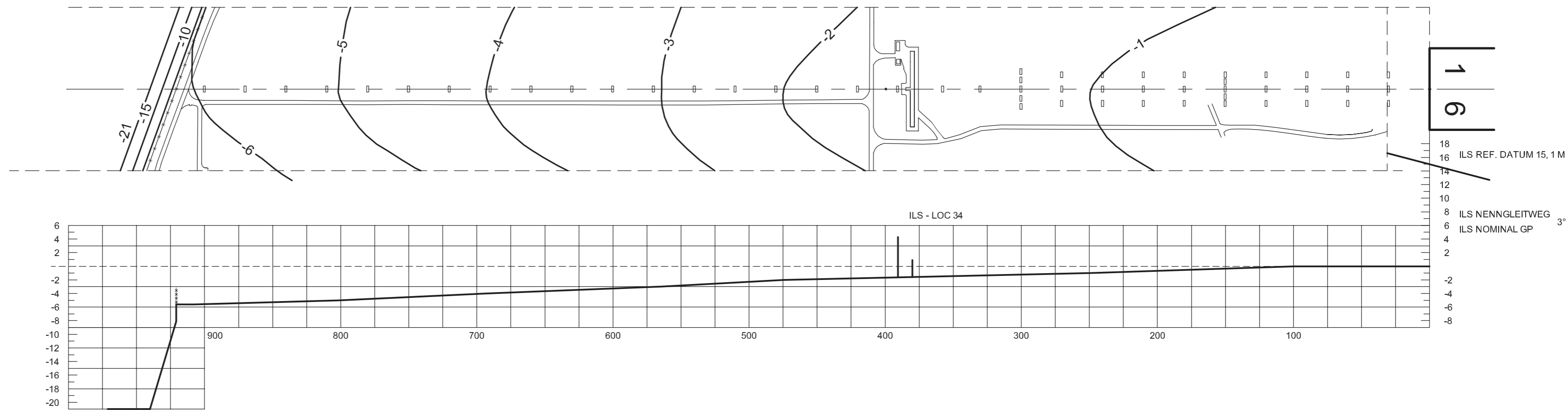
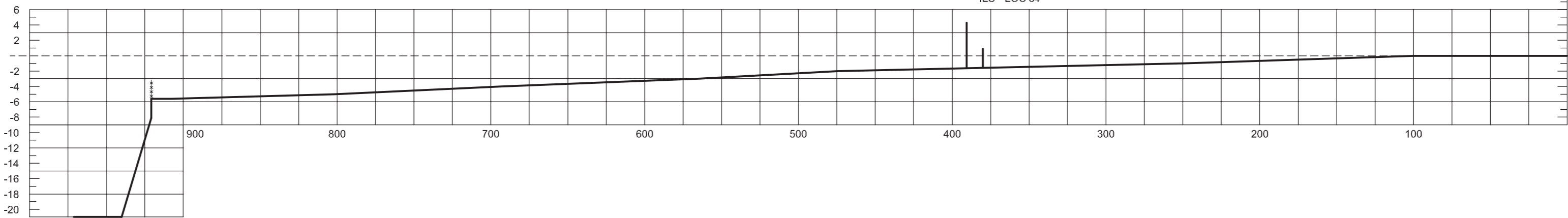

HORIZONTALMASSTAB
HORIZONTAL SCALE
1 : 2 500

| BERICHTIGUNGEN | | AMENDMENTS |
|----------------|---------------|------------------------------------|
| NO. | DATUM DATE | BILDFLUG-DATUM PHOTOFLIGHT-DATE |
| | | 2007 |

| LEGENDE | | LEGEND |
|--|---------|--|
| GEBÄUDE | ■ ■ | BUILDING |
| STRASSE | ==== | ROAD |
| ANTENNE | ● ■ | ANTENNA |
| ANFLUGFEUER | □ ↑ | APPROACH LIGHT |
| PROFIL DER VERLÄNGERTEN PISTENMITTELLINIE | — — — — | PROFILE OF EXTENDED RWY CENTRE LINE |
| HÖHENSCHICHTLINIE | ~ 5 ~ | CONTOUR |
| ZAUN | -X-X-X- | FENCE |